

Weighing Amplifier/Digitiser Module

Features

- Variable gain Strain Gauge sensitivity from 0.5 to 200mV/V
- Simple one pass Auto Calibration
- Auto Tare
- 4-20mA and 0-10V outputs
- 10V @ 160mA excitation to drive up to 6/350 ohm Strain Gauges
- High accuracy
- Low drift
- Wide range of power supplies
- IP65 surface mounting case
- Isolated analogue outputs
- 10 years data retention
- Digital programming, calibration & display



Introduction

The intelligent Strain Gauge amplifier offers both 4 to 20mA and 0 to 10 volt analogue outputs, from any standard Strain Gauge input. 1 pass calibration and setting of the analogue output range, make the unit extremely user

friendly; being set up by a simple hand held or on board programmer/display. Auto Tare and Peak Hold (if set) on the analogue output are operated via volt free contact closures.

Output Options include

- **Relay Set Points** (LR1)
Programmed in engineering units, with In Flight compensation and Hysteresis Settings available for control or alarm purposes.
- **Communications**
To read any value, change set points or any other parameter via:
20mA Current loop (LC1)
RS232/RS485 (LC3)
Format MANTRABUS, ASCII, MODBUS RTU
- **Printers**
Activated by a function key or contact will allow print, the current live value, with header message, engineering units, auto incrementing batch number and real time if required.
- **Options**
9-32V DC power supply (LS3)
Stainless Steel case sealed to IP65 (LSS)
Available without its case as a separate Eurocard PCB assembly (LCB)

Intelligent Strain Gauge Amplifier

The Strain Gauge amplifier is housed in a light grey ABS case, sealed to IP65 with external dimensions of 200 x 120 x 75mm. The unit comprises an intelligent base unit with 4-20mA and 0-10V analogue outputs, and plug in module positions for the power supply, relay and communications options.

The AC power supply is a selectable 115 or 230V AC. Connections for input, output and power supply are through cable glands sealed to IP65. Internal 2.5mm screw field terminals are provided.

The Units offer: Calibration

A simple 1 Pass Auto Calibration is achieved by entering the values of the lowest and highest weights used. Analogue output is pre calibrated and can be set over any part of the displayed range.

Both input and output are calibrated by use of the programmer module. The programmer defaults to weight display to ease calibration checks. Auto Tare (zero) and Peak Hold are actioned by volt free contacts.

Specifications

Inputs

The input is of the Load Cell/Strain Gauge type. With transducer excitation voltage of 9.6 volts @ 160mA to drive 6 x 350R bridges. Compensation by \pm sense wires for cable and safety barrier losses down to 3V excitation. Load cell sensitivity is preset via DIL switches to 0.5, 0.8, 1.0, 1.25, 1.5, 2.0, 2.5, 3.5, 5, 10, 20, 50, 100 or 200mV/V. Initial offset is no greater than ± 0.15 mV (15 μ V/V) which is cancelled during auto calibration.

Speed is 100 readings per second with a digital filter to reduce speed

Accuracy is 90 days $\pm 0.08\%$ of reading, $\pm 0.05\%$ FSD being typical

Drift is 0.002% per degree C @ 2.5mV/V typical

Resolution 15 bit / 4.5 digits

Contact inputs are available for auto tare, print and peak hold reset and are volt free

Analogue Outputs

Drive	4-20mA up to 1Kohm and 0-10 volts up to 2mA
Accuracy	4-20mA + 0.15% of range, typical. 0-10V $\pm 2\%$ before calibration
Resolution	as for display up to 13 bits/4.5 digits. Settling time 350mS to within 1% of step change
Isolation	$\pm 130V$ RMS or DC max to analogue input or any other port

Power Supplies

LS1	110V-120V AC or 220/230V AC 50-60Hz 10W
LS3	9-32V DC 10W isolated

Data Retention/Protection

Retention:	10 years for set up values, minimum of 100,000 write cycles.
Protection of data and function(s):	Watchdog timer giving repeat auto resets. Impending power detection and hold off. Keypad security and time out.

CE & Environmental

Storage temperature	-20 to +70°C	EMC Emissions	BS EN 55011:1998
Operating temperature	-10 to 50°C		
Relative humidity	95% maximum non condensing	EMC Immunity	BS EN 61000-42:1995
Safety/Low Voltage Directive	73/23/EEC amended by 93/68/EEC BS EN 61010-1:2001, IEC 1010-1-1990		BS EN 61000-4-3:2002 BS EN 61000-4-4:2004
EMC Directive	89/336/EEC Basic Standard BS EN 61326:1998		BS EN 61000-4-11:2004

Other Options & Accessories

2 Set Points	Output through 5A 240V AC SPCO Relays, with a latching option
Communications Port	For data transfer or print via :-
20mA loop	Enabling up to 254 units to be multi dropped to 1 x RS232 via IF25 interface(s)
RS485	Enabling up to 25 units to be multi dropped
RS232	For 1 to 1 connection and standard printer drive
Printer Operation	By closure of volt free contact
Baud Rates	300, 600, 1200, 2400, 4800, 9600 (19200 MANTRABUS only)
Die Cast Case	Sealed to IP65 with external dimensions of 220 x 120 x 80mm max
Stainless Steel Case	Sealed to IP65, with external dimensions of 224 x 160 x 90mm
DC Powering	9-32V dc
PCB Only (Eurocard) (LCB)	100 x 160 X 57mm for rack or customers enclosure

Physical

PCB Case Dimensions	120 x 200 x 75mm (without glands, see diagram below)
Case	ABS

LCB Clearance Dimensions

Clearance above the top of LS1 ac power supply	52mm
Clearance above the top of keypad	50mm
Clearance above the LS3 dc power supply	42mm
Clearance below the LCB 3mm, but needs to be insulated to allow 6mm	

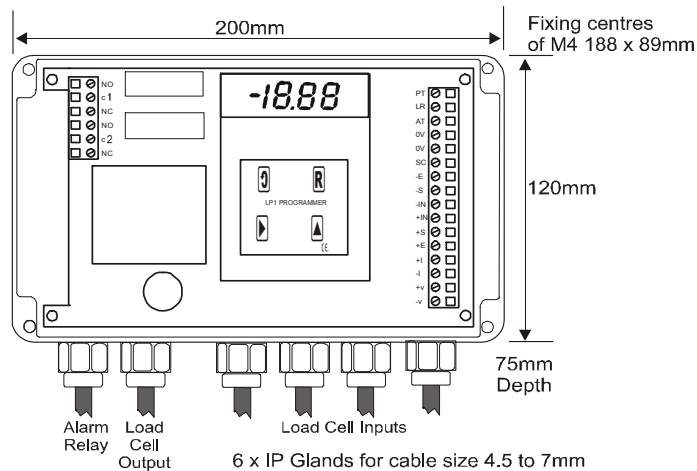

CE In the interest of continued product development, Mantracourt Electronics Limited reserves the right to alter product specifications without prior notice.